

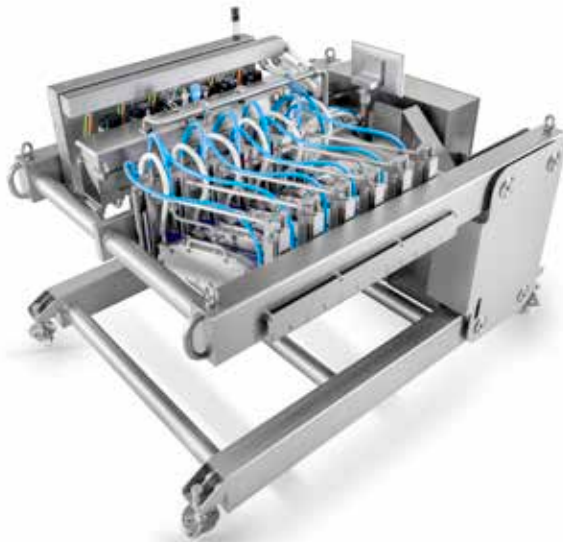

MDL

Mobile Depositor Large

.....



Moveable frame

The MDL is a moveable C-frame that can hold up to eight FJ26 depositor heads with its mass supply piping, pumps, buffer tank and control cabinet. The frame can be docked onto an existing conveyor system. The entire frame is IP67, sanitary design with minimal cabling outside the frame. It is built for extreme harsh environments regarding handling and cleaning. The entire liquid foodstuff circuit is CIP-able without the need for disassembly.

Flexible depositing

The heads are positioned over the flow of passing products, so the liquid foodstuff can get deposited in any position and shape. Each individual head can deposit on 200mm wide section of the conveyor system, and these ranges connected form a total printing width to cover products positioned randomly on the conveyor belt.

Highly accurate deposit weight

Weight control is done by means of servo-driven volumetric pumps. One pump is connected to a designated depositor head with a fixed pipe. The servo controller calculates the pump's rotations, based on forward information of the patterns to be printed and feedback from the pressure sensor integrated in the depositor head. This way, a highly accurate deposit weight can be guaranteed, even when liquid density fluctuations occur during long production runs.



MDL

Mobile Depositor Large

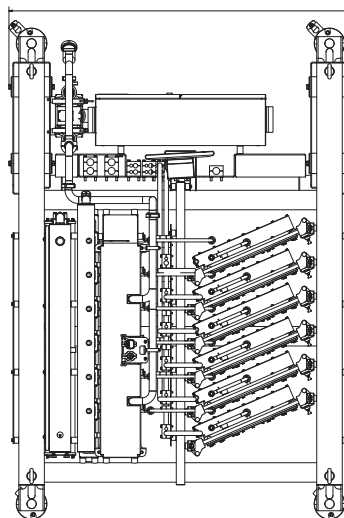
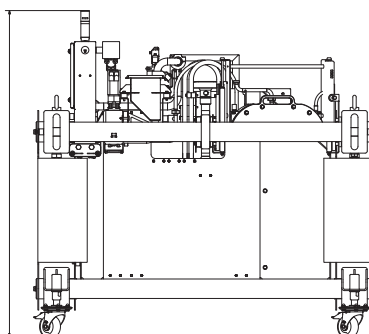
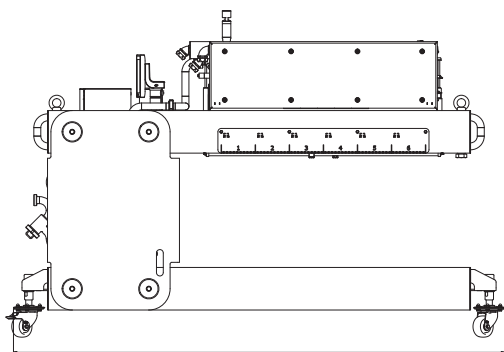

Technical specifications:

- Available in 800, 1000, 1200, 1400 and 1600mm depositing widths.
- Available with illuminated vision camera hood on entry side.
- Operator functionality: recipe control, on the fly weight and position adjustments.
- Beckhoff EtherCAT PC and HMI.
- SEW servo motors on rubber impeller pumps.
- Electrical connection 3x400VAC + PE, 5kW.
- UL & CE certified.

WWW.FOODJET.COM



Ambachtsweg 49 | 6541 DA Nijmegen
The Netherlands | T +31 24 3790061
info@foodjet.com | www.foodjet.com

FOODJET
PRECISION DEPOSITING SOLUTIONS